

# **Futuuri- service evaluation framework**

## **Module: Revenue logic and finance**

### **Change history:**

Version	Date	Made by	Comments
0.1	1.6.2005	P.Kallio	Initial draft
0.2	15.6.2005	P. Leviäkangas	Inserted text
0.3	24.3.2006	A. Wallin	Inserted text and figures
0.4	20.09.2006	A. Wallin	Inserted example

## INDEX

1. Aim and purpose.....	3
2. Definition of scope and views of the evaluation .....	3
2.1 Defining actors and their interaction in value network .....	4
2.1.1 Model for describing value network and revenue logic .....	5
2.1.2 General level telematics value network.....	5
2.1.3 Detailed examples of describing value network.....	7
2.2 Life-cycle phase of the service .....	8
3 Profitability evaluation .....	9
3.1 General profitability of the service .....	9
3.2 Supplementary calculations and analysis .....	10
3.2.1 Investment evaluation key ratios .....	10
3.2.2 Option values.....	10
3.3 Required return on investment, discounting rate.....	11
4 Finance .....	12
5 Actor change impacts .....	13
6 Evaluation methods and metrics.....	13
7 Results .....	13
8 Conclusions .....	13
9 Connection to other modules.....	13
References .....	14

# 1. Aim and purpose

The aim of the module “revenue logic and finance“ is to:

- aid in the evaluation of the financial profitability of the whole service,
- aid in the evaluation of the financial profitability of the service to each individual actor of the service
- provide help to derive financial key figures (like breakeven point) to form basis for the profitability evaluation of the service
- aid in the evaluation of financing options for investments needed to establish the service
- aid in the evaluation of more complex issues related to the investments and establishment of the service

# 2. Definition of scope and views of the evaluation

The evaluation process of the service in this module includes the following phases presented in Figure 1.

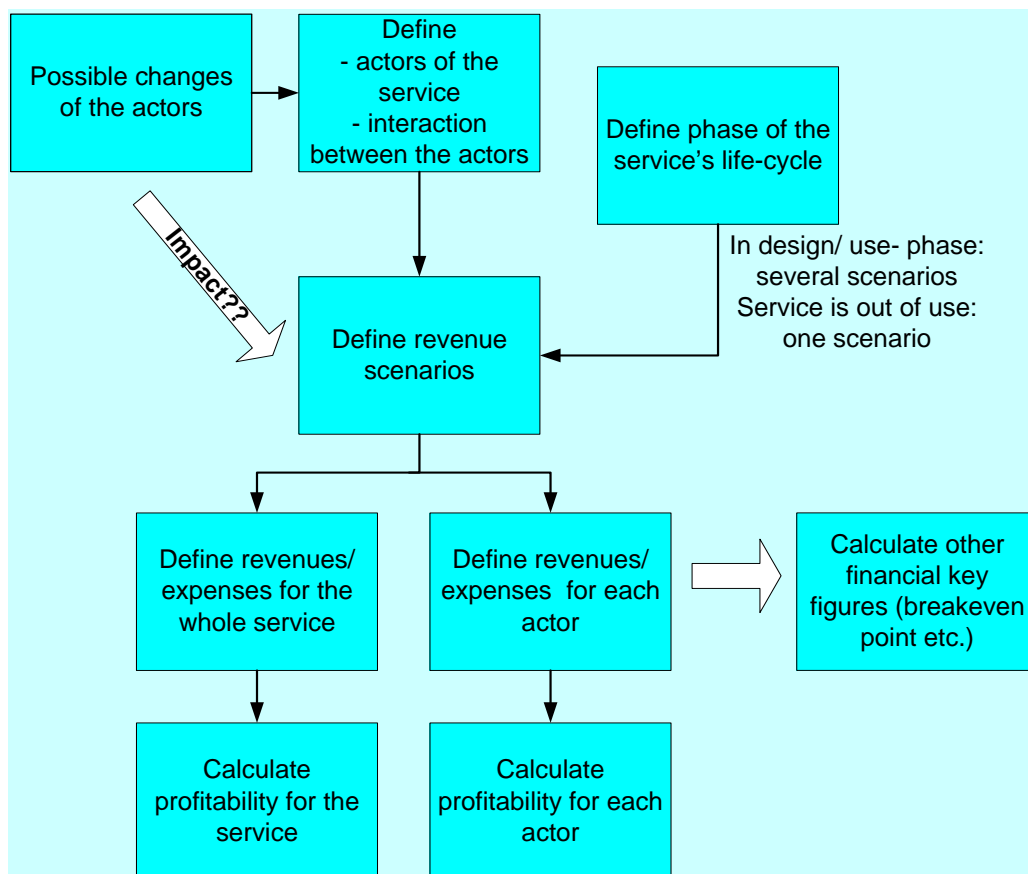

**Figure 1.** Evaluation process of the service in module “revenue logic and finance”

The phases of the evaluation process of the service are explained in more detail in the following sections.

## 2.1 Defining actors and their interaction in value network

In the value network there can be a number of different firms which all have different relationships with each other. Where Coase (1937) has defined only two main relationship types: markets and hierarchies (vertical integration), has Williamson (1975) defined also an intermediate relationship type called hybrid. The hybrid structure can be defined as a partnership (Blomqvist et al. 2002). In the value network firms have different kinds of partnership and coalition relations with each other.

In business networks the business actors perform activities and create value through transforming resources such as know-how or capital (Anderson & Narus 1999). Companies' network is a long-term, purposeful arrangement among distinct companies that allows them to gain competitive advantage over their competitors outside the network (Anderson & Narus 1999). Cooperation between business actors occurs in business networks that change dynamically over time and usually lack a given centre (cf. for example Håkansson & Snehota 1995), although, in some cases one actor is the centre of the business network (NTT DoCoMo 2004). The value of a network increases in proportion to the square of the number of nodes on the network, which means that the more subscribers the network has the more valuable it is (Kallio 2004).

The business networks have the following benefits:

- zero inventory, distribution, product merchandising and marketing costs,
- near zero product liability, content development, marginal growth costs and revenue risk, and
- focusing on networks makes the final total cost of the product/service lower because of the diminished transaction costs (Jarillo 1988).

In the open market, i.e. agora, (see Figure 2) anyone can buy/sell and no single entity is in control. On aggregation one company usually leads in hierarchical fashion, positioning itself between customers and producers. Distributive Network businesses are the infrastructure of the entire economy; they provide the backbone for the digital economy – communications, bandwidth, delivery services, banking services, etc. Alliances have no hierarchy in control; no one can force anyone to be a part of it, one can leave anytime. Instead, a few rules and standards evolve which governs how the Alliance works. In a value chain the focus is on process optimization and there is one primary company that maximizes value integration. (Tapscott et al. 2000)

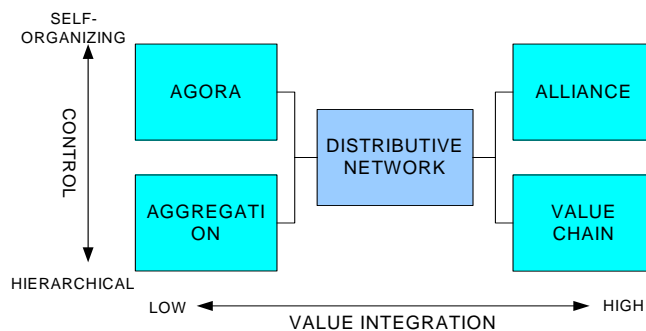

**Figure 2.** B-web typology (Tapscott et al. 2000).

### 2.1.1 Model for describing value network and revenue logic

Defining the business actors starts by defining actors of the service and product-, information- and monetary flows between them in general level as presented in Figure 5 below.

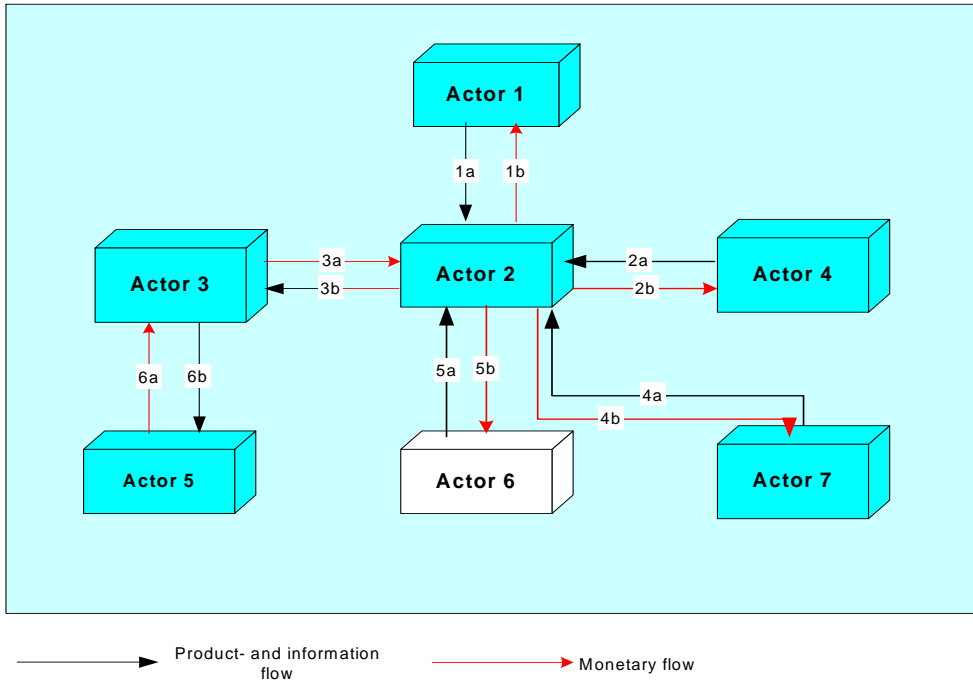

*Figure 3. Example of description of service actors and flows between them*

After specifying the actors and their interaction, define the interaction of the actors in more detail in the form of table as presented in Table 1 below. The aim is to describe what each actor delivers to others and how/what the other actor receiving the flow, pays for it.

*Table 1. Flows in the service*

Nr of the flow	Direction of the flow	Revenue logic
1a, 1b	Actor 1 ↔ Actor 2	Actor 1 delivers actor 2 product x and actor 2 pays for it y €/piece for it
2a, 2b	Actor 2 ↔ Actor 4	..
...		

### 2.1.2 General level telematics value network

General level value network for traffic telematics services consists of basic data and information producers, data refiners, information distributors and end users. At the beginning of the value network basic data for telematics services is produced. Information

is either in the format of raw data or pre-processed data. Data refiners process and combine raw data and/or pre-processed information to create value added services. Information provided by the services is distributed to end customers from service providers. Finally end users are the ones who make use of information provided by the service (FITS 2003).

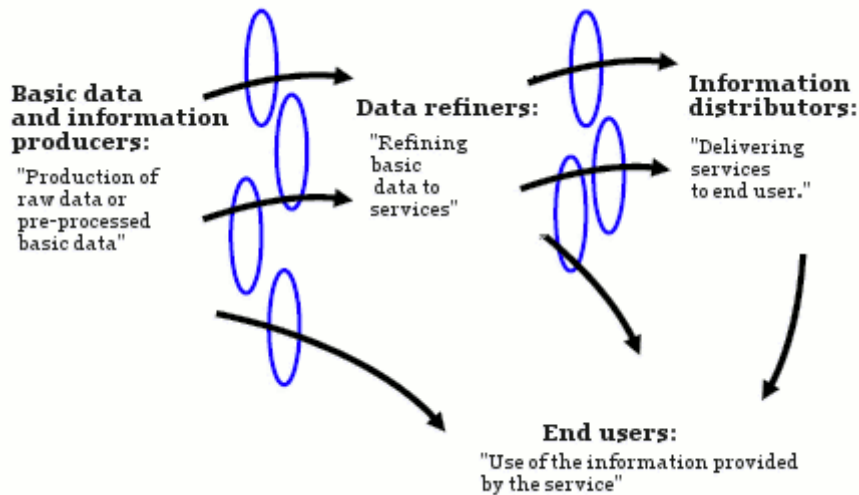

*Figure 4. Value network for traffic telematics products and services*

Value network of general collaboration model for public and private sectors is illustrated in Figure 4. Responsibilities for providing services are divided to public sector and private companies. Content is owned usually by public sector. Content providers are either from public sector or they can also be private companies. In this model, private sector is responsible for tasks of service operator and service providers. Operators of computer and networks provide infrastructure for the other actors in the network. Infrastructure providers can be either from public or private sector (LVM 2002).

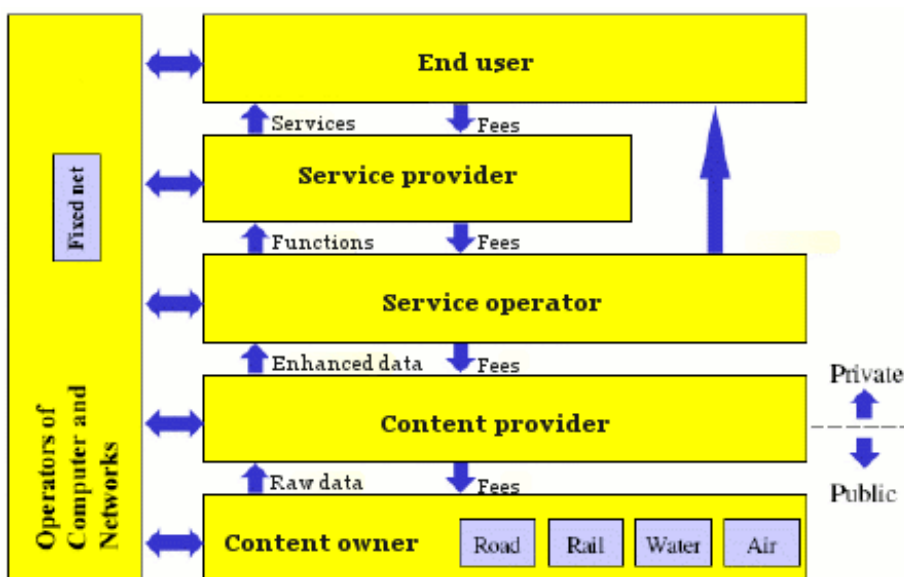

*Figure 5. Value network of general collaboration model for public and private sector*

### 2.1.3 Detailed examples of describing value network

Two case services described in (Kallio 2004, pp. 42-45) are good examples how to use description model introduced in section 2.1.1. These examples illustrate how business roles, revenue logic and transaction flows should be described. Functions of wireless business models and business roles are also presented in the paper.

Another, more traditional way of describing value network, is case Digiroad that is depicted in Figure 6. It is an illustrative example of the value network for traffic telematics systems. The Digiroad is a national information system, which contains exact locations and most important features for whole road network of Finland. Although this model does not identify transaction flows and revenue logics, there are many similarities between the value network of Digiroad and the model that is introduced in section 2.1.1. For more information about Digiroad see <http://www.digiroad.fi> (in Finnish).

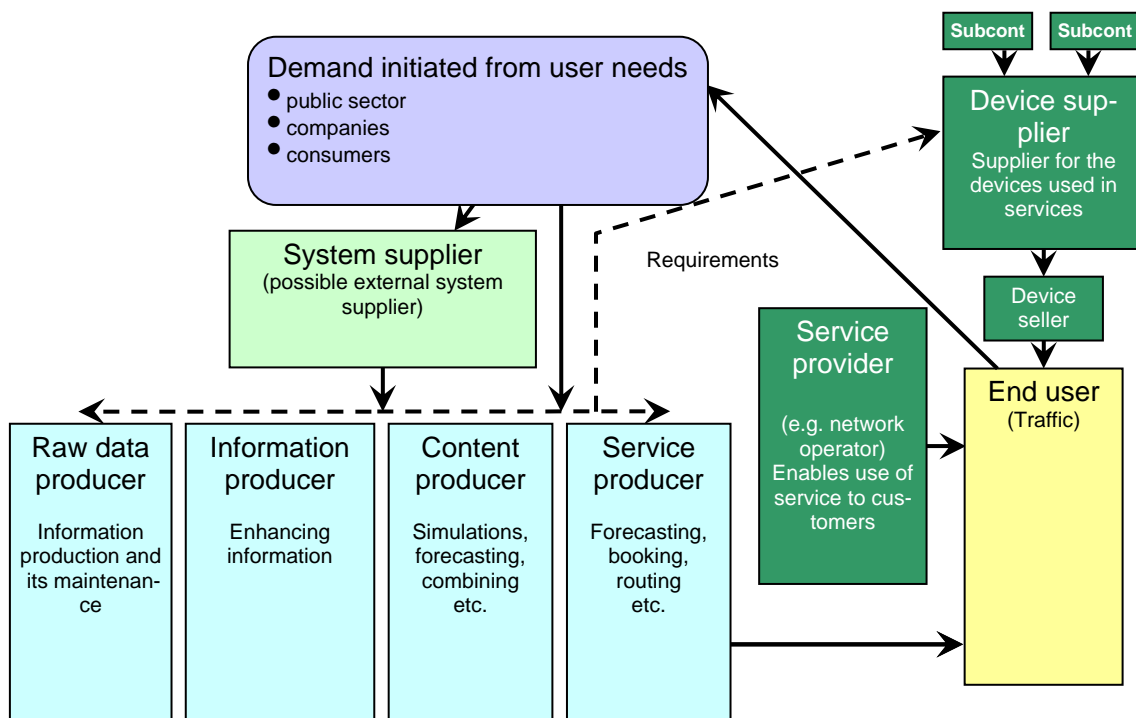

Figure 6. Case Digiroad: value network

## **2.2 Life-cycle phase of the service**

Define on which phase of the life-cycle the service is:

- a) *Development phase*, i.e. requirements specification, architectural design, implementation and testing (Adamaopoulos et al. 2000, Jaring et al. 2004). In this phase business actors earn revenue by selling application/ content to other business actors.
- b) *Deployment phase*, i.e. installation and activation of the service (Adamaopoulos et al. 2000); in this phase business actors earn revenue by implementing the service and needed infrastructure and terminals.
- c) *Usage/ provisioning*, i.e. provisioning of the service and its use by end users; in this phase business actors earn revenue by providing the service to the end user.
- d) *Maintenance phase* that includes all the activities required evolving a service over its lifetime; in this phase business actors earn revenue from maintenance of the service. (Kallio 2004)

In case the service is on phase a)-c), there are several possible revenue-scenarios that all should be calculated. In case the service is on phase d)- the revenue-scenario is calculated afterwards based on real values.

### 3 Profitability evaluation

#### 3.1 General profitability of the service

Define profitability of the service by making profitability calculation for it. For making the profitability calculation, estimate the expenses and revenues of the service and the residual value of the investments by defining ALL expenses and revenues of the service.

Note that in the actor network some actor's cost represent some other's revenue and *vice versa*. In value network analysis, it is recommended to calculate profitability for each actor.

Table 2 below presents some examples of the expenses and revenues of a service.

**Table 2.** Expense/revenue-division of a service

Expenses (€)	Year 1	Year 2...	...Year n
Running expenses			
Maintenance expenses			
Investment expenses			
Other expenses			
.....			

Revenue (€)	Year 1	Year 2...	...Year n
Sales revenue (amount of users * price)			
Cost savings			
Other revenue			
.....			

<b>Residual value of the investments</b>	-	-	in Year n
--	---	---	-----------

After defining the expenses and revenues calculate the

$$Net\ Cash\ Flow\ (NCF) = Revenues - Expenses$$

on an annual basis.

The *Net Cash Flow* can then be used when determining the *Internal Rate of Return (IRR)* for the investment or project. (See any standard investment theory text book). If  $IRR >$  the required return on investment or project, the investment / project is profitable.

*Benefit-Cost ratio (B/C)* is the ratio of the sum of discounted *Revenues* divided by sum of discounted *Expenses*. The discounting rate is the required return on investment or project. If  $B/C > 1$ , the investment / project is profitable. (See any standard investment theory text book).

*Net Present Value (NPV)* is the net sum of discounted *Revenues* and *Expenses*. If  $NPV > 0$  the investment / project is profitable.

The discounting rate should be the *Weighed Average Cost of Capital (WACC)* for each actor (see any finance text book). A good proxy for this is the actor's required return on investments. For more advanced analysis, see section "Finance".

For public investments / projects and socio-economic analysis all the above methods apply but some of the *Revenues* and *Expenses* items may be more intangible, e.g. the value of travellers' or goods' time.

## **3.2 Supplementary calculations and analysis**

### **3.2.1 Investment evaluation key ratios**

This section presents some optional calculation of financial key figures that the evaluator may want to know when evaluating the service.

**Breakeven point:** In case the evaluator wants to know breakeven point of the service, i.e. how many users the service should have to be profitable. Breakeven point is calculated in the following way:

$$\text{Amount of users in Breakeven Point} = \frac{(\text{Costs of the service} - \text{other revenues})}{\text{Price of the service}}$$

**Payback time:** *Payback Time* tells the evaluator how long time it takes for *Revenues* to cover the *Investment*.

$$\text{PaybackTime} = \frac{\text{Revenues}}{\text{Investment}}$$

*Payback Time* as well as *Breakeven Point* requires present value analysis and use of proper discounting rate.

### **3.2.2 Option values**

Option values may be significant if the choice of investing (or proceeding with the project) results in a series of new opportunities or close down some previously available opportunities (Figure 4). Option analysis can be carried out as such or as part of e.g. *multicriteria analysis*.

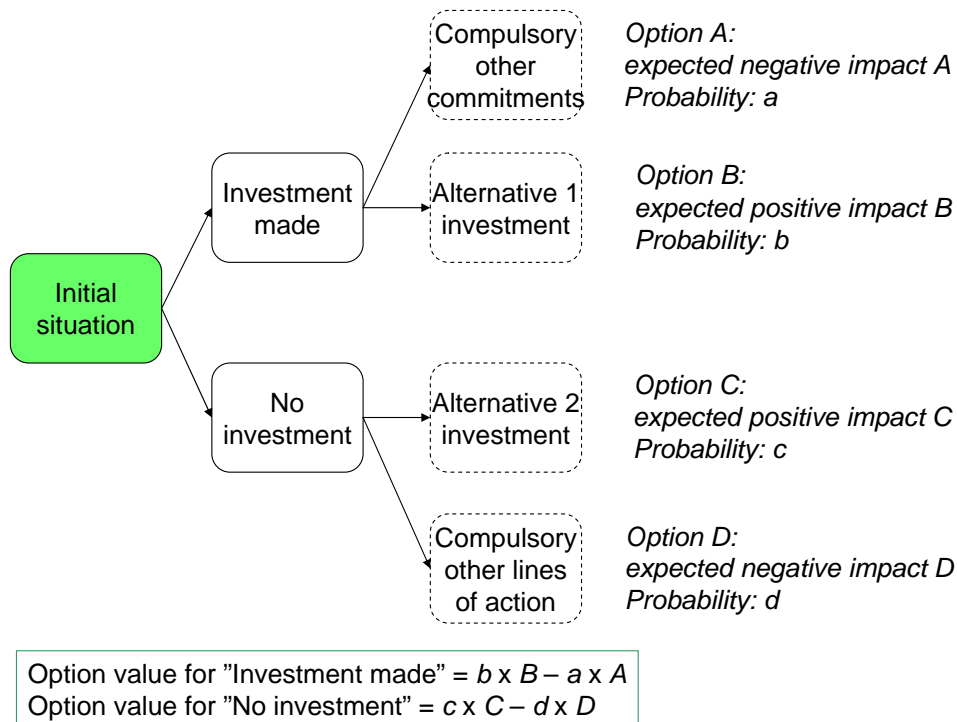

**Figure 7.** Option values in an investment decision making situation

The following, for example, may be regarded as options with calculable value:

- possibility (or no possibility) to postpone investments (the actual investment in question or other investments as a result of individual investment decision)
- possibility (or no possibility) to have numerous other alternative lines of action available after individual decision
- possibility (or no possibility) to abandon or resell investment.

### 3.3 Required return on investment, discounting rate

The *Required Return* on investment is the same as the *Discounting Rate* to be used in present value calculations. What is "required return" depends on the following:

- the risks related to the project or investment
- the line of business and industry
- the will of investors or decision makers
- the capital structure impacts of the investment (whether there is need for new debt or equity for the investment or project).

**Table 3.**

	Identified risks		Line of business / industry	
	Low	High	Risky	Low Risk
Required Return	-	+	+	-

+ = higher return, - = lower return

For public sector the *Social Discounting Rate* should be used. This is usually a decided discounting rate for all public investments in a particular public sector or country.

## 4 Finance

The financing decisions are separate from the profitability analysis. Therefore, interest payments on capital (debt and equity) as well as the capital flows should be kept aside from profitability analysis (Figure 5). However, it may be necessary to consider financing if new capital is needed for the establishment of the service (investment or project) or especially if a separate service or project company is to be build to provide the service.

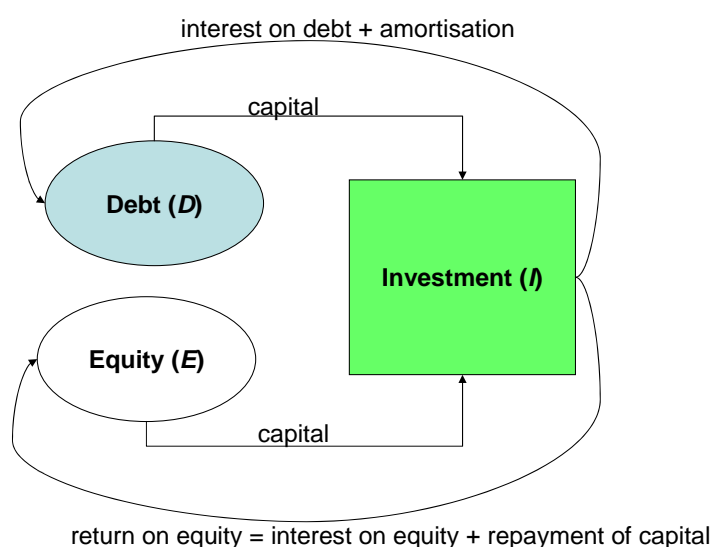

**Figure 8.** Two basic forms of capital to finance an investment or a company: debt and equity

Note that the financing decisions especially when significant new capital is needed will impact on the *Required Return* and *Discounting Rate*. For each business, an optimal financing structure exists that maximises the value of investment (*NPV*), depending on

- risks related to the project / investment / service
- tax advantages

**Table 4.**

	Risks		Corporate tax rate	
	High or Significant	Low or Insignificant	High	Low
Equity investors prefer	More debt, less equity	Less debt, more equity	More debt, less equity	Less debt, more equity
Debt investors try to	set higher interest	set lower interest	-	-

## 5 Actor change impacts

It is possible that the amount or division of actors can change in value network, i.e. actors can enter/ leave the value network. It may be necessary to define the impact of the change on the revenue logic/ profitability of the whole service and individual actors.

To define the impact of an actor change, the following issues should be addressed:

- Identify changed actor or changed role
- Assess the relevance or severity of the change
- Assess the impact of change on profitability of the whole service/ individual actors; where does it affect and how much?
- Assess other prospective impacts.

## 6 Evaluation methods and metrics

- investment analysis methods; B/C, NPV, IRR, Du Pont
- multicriteria analysis
- option theory
- financial theory

## 7 Results

As financial profitability of the service pretty much defines whether the service is worthwhile to realize or not, and who should participate in investing and build-up of the service. Profitability key ratios assessed for each actor are used to judge this. The ratios could (and probably should) be supplemented with other profitability and financial impact analysis. Multicriteria analysis is a good tool for this.

## 8 Conclusions

-

## 9 Connection to other modules

This module is bi-directionally linked with modules

- *Organisation*
- *Productivity and Efficiency*
- *Market Analysis*
- *Risk Analysis.*

## References

Adamopoulos, D., Pavlou, G., Papandreou, C., 2000. Development of New Telecommunications Services in Distributed Platforms. Proceedings of the IEEE International Conference on Communications (ICC '00), New Orleans, USA, Vol. 1, June 2000. Pp. 222-226.

Anderson, J. C., Narus, J.A., 1999. Market Management: Understanding, Creating and Delivering Value. Upper Saddle River, NJ: Prentice Hall, 1999.

Blomqvist, K., Kyläheiko, K., Virolainen, V-M., 2002. Filling the gap in traditional transaction cost economics: Towards transaction benefits-based analysis, International Journal of Production Economics, vol. 79, pp. 1-14, 2002.

Coase, R. H., 1937. The Nature of the Firm, *Economica*, vol. 4, pp. 386-405, 1937.

Cox, A., 1997. Business success: a way of thinking about strategy, critical supply chain assets and operational best practice. Witheringham: Earlgate Press, 1997.

FITS. Liikennetelemaattisten tuotteiden ja palveluiden pelisäännöt. Vol 13, 2003. Helsinki: Liikenne- ja viestintäministeriö.

Håkansson, H., Snehota, I., 1995. Developing Relationships in Business Networks. London: International Thomson Business Press.

Jarillo, J. C., 1988. On Strategic Networks, *Strategic Management Journal*, vol. 9, pp. 31-41.

Jaring, M., Krikhaar, R.L., Bosch, J., 2004. Representing variability in a family of MRI scanners. *Software: Practice and Experience*. Vol. 34, Issue 1, 2004. Pp. 69-100.

Kallio, P. [Emergence of wireless services- business actors and their roles in networked component-based development](#) (doctoral dissertation). VTT Publications 534, Espoo, Finland, 2004. ISBN 951-38-6386-7, ISSN 1235-0621. 118 p. + app. 83 p.

Liikenne- ja viestintäministeriö, 2002. Katsaus multimodaaliin liikennetiedotukseen.

NTT DoCoMo; "Business strategy", Retrieved 5-3-2004 World Wide Web, <http://www.nttdocomo.com/corebiz/imode/why/strategy.html>.

Sharma, C., Nakamura, Y., 2003. Data Services- Technologies, Business Models and Global Markets. Cambridge University Press.

Tapscott, D., Lowy, A., Ticoll, D., 2000. Digital Capital - Harnessing the power of business webs. Boston, Mass: Harvard Business School Press.

Williamson, O. E., 1975. *Markets and Hierarchies: Analysis and Antitrust Implications, A Study in the Economics of Internal Organization*. New York: Free Press, 1975.